

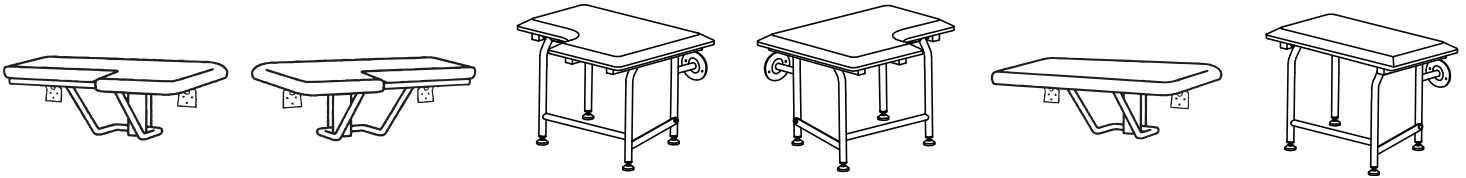

FOLDING SHOWER SEATS



Included Materials

- One (1) seat assembly with attached wall brackets
- One (1) middle support “slide” bracket (**NOT** on seats with legs)
- Six (6) to Eight (8) ¼” X 2 ½” stainless steel screws (qty. depends on config.)

Tools and Materials (not included)

- Drill - electric or manual
- ⅜” drill bit
- ¼” drill bit
- 24” level
- Silicone caulk

⚠ Safety Cautions

- Due to variance in local building codes and requirements, the guidelines laid out here are suggestions **ONLY**. It is **STRONGLY ADVISED** to **ONLY** contact a qualified contractor for application specific advice.
- Folding Shower Seats are **ONLY** as strong as the material(s) to which they are mounted.
- This seat is intended for seating one person at a time. **DO NOT** attempt to stand, kneel, or use the seat for any other purpose than for sitting.
- The folding seat is designed to support up to 400lbs with wall brace and up to 600lbs with legs when properly installed to a strong surface. Improper installation may lead to bodily harm.
- **IMMEDIATELY** discontinue use of the seat if visual signs of fatigue or wear become evident. Regular inspections should be made to confirm that the seat is **NOT** pulling away from the wall. If the wall brackets start to pull away, stop and contact a qualified contractor for repairs.

Preparation

Check local codes for proper placement of fold down shower seating to meet ADA and/or ANSI 117.1 Consumer Safety Requirements or other regulations you may be required to meet.

Before installing the Folding Shower Seat, you will need to prepare the area.

ROUGH-IN INSTALLATION:

Determine where the Folding Shower Seat will be mounted and install the bracing to the rough-in framing to support the seat through the shower wall. Provide no smaller than a 2" X 6" blocking in the wall for mounting. Measure from the sub-floor up 13 1/4". Center the 2" X 6" at the 13 1/4" mark.

Notch the wall studs to accommodate the header and attach with no less than Six (6) 5/16" X 3" stainless steel screws. (Fig. 1a).

Before finishing the wall and using the dimensions of your seat, ensure that the two upper mounting brackets and the top two screws of the guide bracket align with the 2" X 6" blocking, while the third bottom screw of the guide bracket will line up with the middle and wall stud (Fig. 1b).

If you are installing a seat with legs, no center support is required for setup and installation.

Finish the stud wall with tile, fiberglass, or other decor.

EXISTING WALL INSTALLATION:

Locate the stud behind the existing shower wall and determine where the Folding Shower Seat can be safely mounted. Both the upper mounting bracket and the guide bracket **must** be in contact with the studwall. Clean the portion of the shower wall where the seat will be installed.

Installation

NOTE: When installing a leg-supported seat, the guide bracket is not required. The two upper mounting brackets are centered on the 2" X 6" blocking with the four legs siting firmly on the floor. All four legs are adjustable with locking feet. It is recommended to adjust the two front feet so that the seat tilts upwards 2° - 3° from the wall to the front edge. Once positioned, tighten the lock nut to prevent slipping.

Step 1:

Locate the desired seating position making sure that the top of the seat is between 17" - 19" from the finished floor. When measuring, the seat must be in the downward, seating position. With a 24" level, measure the side-to-side alignment to ensure the seat is level, and front-to-back is at a 2° - 3° incline.

Step 2:

Use a pencil to mark the locations for the three screw holes from each of the upper mounting brackets, and the three holes from the guide bracket (legless seats only). Be careful of its position: the bottom screw of the guide bracket needs to be centered on the middle wall stud with the top screws fastened to the 2" X 6" block (Fig. 2).

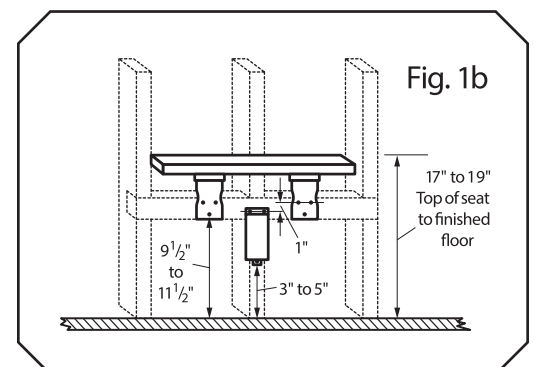
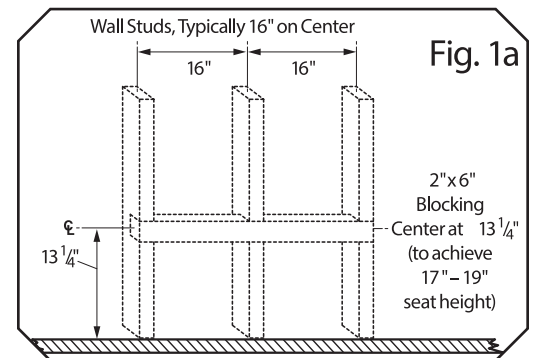

Step 3:

Remove the seat. In each marked location, use a ¼" drill bit to make clearance holes through the tile only. Then drill ⅜" pilot holes through the header board and attach the seat using ¼" X 3" stainless steel screws. Use a generous amount of silicone caulk to prevent water from seeping into the mounting holes.

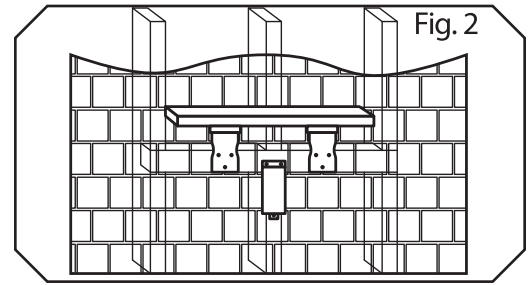

Step 4:

Make sure that the seat raises and lowers smoothly. If correctly installed, the seat will remain in the upward, closed position on its own and it will require little effort to be lowered into the seating position.

USA 📍 521 Lawrence Rd. NE, Canton, OH 44704 | ✉️ cservice@elcoma.com | ☎️ 1.800.352.6625 | 📠 1.800.625.5560
CANADA 📍 878 William Street, Midland, Ontario L4R 4P4 | ✉️ sales@elcoma.com | ☎️ 705.526.9363 | 📠 705.526.7555