

Adult Teakwood Folding Shower Seats

Rectangle with Legs

Configuration:
62 Series
with legs

Application Use:



Specifications

Folding shower seat manufactured by ELCOMA from 1" (25mm) diameter, 18 gauge and 1.25" x 1.25" (32mm x 32mm), 16 gauge, type 304 stainless steel tubing with #4 satin finish. Wall mount brackets shall be 12 gauge type 304 stainless steel. Slatted Teakwood seat shall be 1/2" (13mm) thick and shall be mildew resistant. Shower Seat shall comply with all applicable federal, provincial and local building and safety codes.

Natural Teakwood finish (yellowish / brownish wood color)



Custom sizes are available to suit special requirements.

24" x 16"	(609mm x 406mm)	Teakwood	Model # 62-TK24WLEG
26" x 16"	(660mm x 406mm)	Teakwood	Model # 62-TK26WLEG
28" x 16"	(711mm x 406mm)	Teakwood	Model # 62-TK28WLEG
30" x 16"	(762mm x 406mm)	Teakwood	Model # 62-TK30WLEG
32" x 16"	(812mm x 406mm)	Teakwood	Model # 62-TK32WLEG
34.5" x 16"	(876mm x 406mm)	Teakwood	Model # 62-TK345WLEG

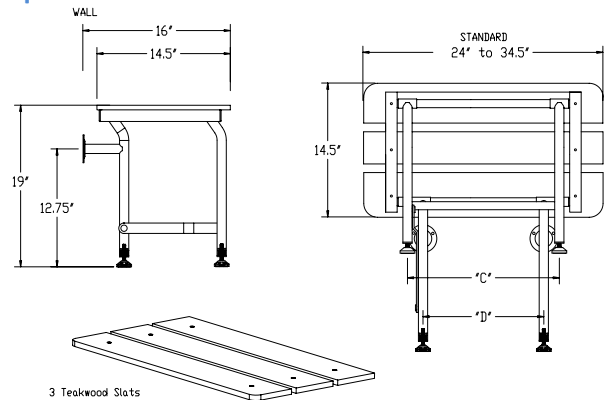

Elcoma Shower Seats have been designed and tested to withstand 600lbs. (272kgs) of load when properly installed.* This exceeds HUD, FHA, VA, ADA, ANSI and other federal, provincial, and local codes. *Shower seats can only be as strong as what they are mounted to. It is imperative when installing any shower seat to consult with a qualified contractor to insure you have sufficient backing.

SEAT SIZE	24	26	28	30	32	34.5"
LEG WIDTH "C"	14.4	16.4	18.4	20.4	22.4	24.9
LEG WIDTH "D"	11.1	13.1	15.1	17.1	19.1	21.6