

Adult Phenolic Folding Shower Seats

Rectangle with Legs

Configuration:
62 Series
with legs

Application Use:

Architectural

Commercial

Institutional

Residential

Specifications

Folding shower seat manufactured by ELCOMA from 1" (25mm) diameter, 18 gauge and 1.25" x 1.25" (32mm x 32mm), 16 gauge, type 304 stainless steel tubing with #4 satin finish. Wall mount brackets shall be 12 gauge type 304 stainless steel. Solid Phenolic seat shall be 1/2" (13mm) thick and shall be fire and mildew resistant. Shower Seat shall comply with all applicable federal, provincial and local building and safety codes.

Woodgrain shown, Also available in white



Custom sizes are available to suit special requirements.

24" x 16"	(609mm x 406mm)	White	Model # 62-PH2401WLEG
24" x 16"	(609mm x 406mm)	Woodgrain	Model # 62-PH2415WLEG
26" x 16"	(660mm x 406mm)	White	Model # 62-PH2601WLEG
26" x 16"	(660mm x 406mm)	Woodgrain	Model # 62-PH2615WLEG
28" x 16"	(711mm x 406mm)	White	Model # 62-PH2801WLEG
28" x 16"	(711mm x 406mm)	Woodgrain	Model # 62-PH2815WLEG
30" x 16"	(762mm x 406mm)	White	Model # 62-PH3001WLEG
30" x 16"	(762mm x 406mm)	Woodgrain	Model # 62-PH3015WLEG
32" x 16"	(812mm x 406mm)	White	Model # 62-PH3201WLEG
32" x 16"	(812mm x 406mm)	Woodgrain	Model # 62-PH3215WLEG
34.5" x 16"	(876mm x 406mm)	White	Model # 62-PH34501WLEG
34.5" x 16"	(876mm x 406mm)	Woodgrain	Model # 62-PH34515WLEG

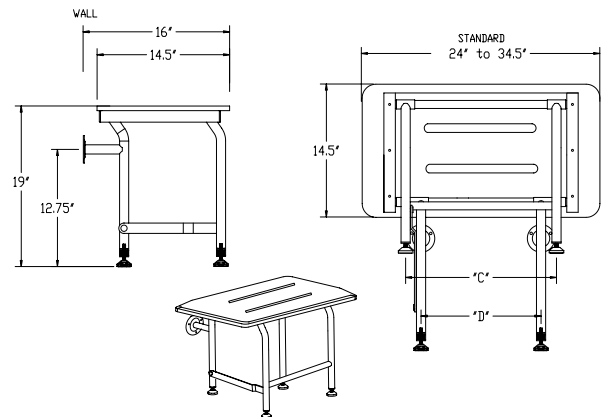

Elcoma Shower Seats have been designed and tested to withstand 600lbs. (272kgs) of load when properly installed.* This exceeds HUD, FHA, VA, ADA, ANSI and other federal, provincial, and local codes. *Shower seats can only be as strong as what they are mounted to. It is imperative when installing any shower seat to consult with a qualified contractor to insure you have sufficient backing.

SEAT SIZE	24	26	28	30	32	34.5"
LEG WIDTH "C"	14.4	16.4	18.4	20.4	22.4	24.9
LEG WIDTH "D"	11.1	13.1	15.1	17.1	19.1	21.6