

Adult Padded Folding Shower Seats "L" shape with Legs (RH/LH)

Configuration:
60/61 Series
with legs

Application Use:



Specifications

Folding shower seat manufactured by ELCOMA from 1" (25mm) diameter, 18 gauge and 1.25" x 1.25" (32mm x 32mm), 16 gauge, type 304 stainless steel tubing with #4 satin finish. Wall mount brackets shall be 12 gauge type 304 stainless steel. Padded vinyl cushion shall have 1.5" (38mm) high density, high resilience foam, covered with fire and mildew resistant, UV inhibited, marine grade naugahyde. Waterproof seam cushions shall have no external piping. Seat unit shall comply with all applicable federal, provincial and local building and safety codes.

**** RIGHT HAND SHOWN , LEFT HAND OPPOSITE ORIENTATION ****



Custom sizes are available to suit special requirements.

26" x 21" (660mm x 533mm)	White	Model # 60-PA2601WLEG
26" x 21" (660mm x 533mm)	Almond	Model # 60-PA2602WLEG
28" x 21" (711mm x 533mm)	White	Model # 60-PA2801WLEG
28" x 21" (711mm x 533mm)	Almond	Model # 60-PA2802WLEG
30" x 21" (762mm x 533mm)	White	Model # 60-PA3001WLEG
30" x 21" (762mm x 533mm)	Almond	Model # 60-PA3002WLEG
32" x 21" (812mm x 533mm)	White	Model # 60-PA3201WLEG
32" x 21" (812mm x 533mm)	Almond	Model # 60-PA3202WLEG
34.5" x 21" (876mm x 533mm)	White	Model # 60-PA34501WLEG
34.5" x 21" (876mm x 533mm)	Almond	Model # 60-PA34502WLEG

Model #61 - (for left hand)

Elcoma Shower Seats have been designed and tested to withstand 600lbs. (272kgs) of load when properly installed.* This exceeds HUD, FHA, VA, ADA, ANSI and other federal, provincial, and local codes. *Shower seats can only be as strong as what they are mounted to. It is imperative when installing any shower seat to consult with a qualified contractor to insure you have sufficient backing.

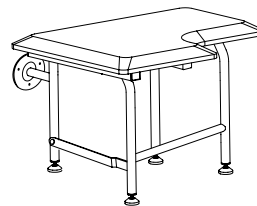
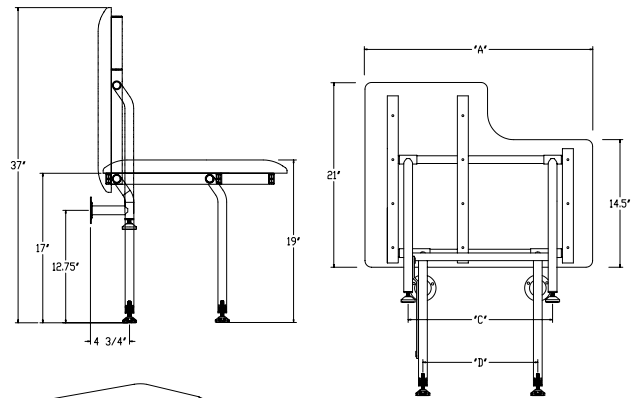

60= Right Hand (shown)
61= Left Hand (opposite)

SEAT SIZE 'A'	26	28	30	32	34.5
LEG WIDTH 'C'	16.4	18.4	20.4	22.4	24.9
LEG WIDTH 'D'	13.1	15.1	17.1	19.1	21.6